

H=29 m
H=36 m

● ○

- S1210 - 1.21x1.21 m
- S1100 - 1.10x1.10 m
- * OPTIONAL

S1100

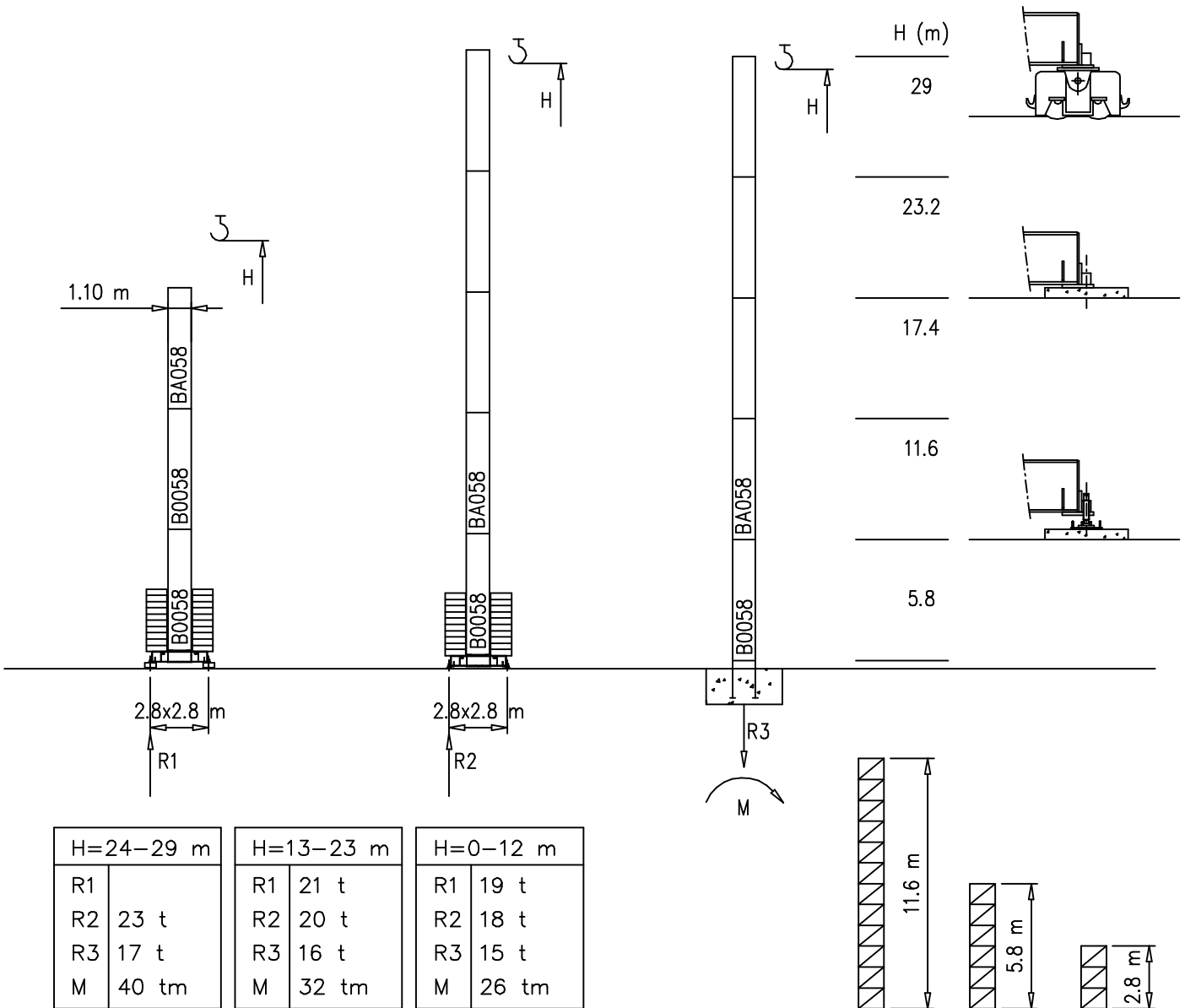

Peso zavorra – Ballast weight – Poids du lest – Ballastgewicht – Peso de lastre

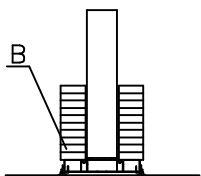

H	n°	Tot.
0–12 m	10 B	22000 kg
13–23 m	12 B	26400 kg
24–29 m	14 B	30800 kg

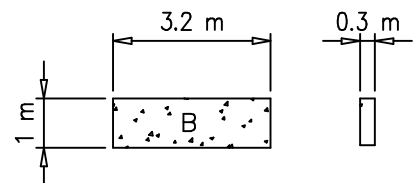

S1210

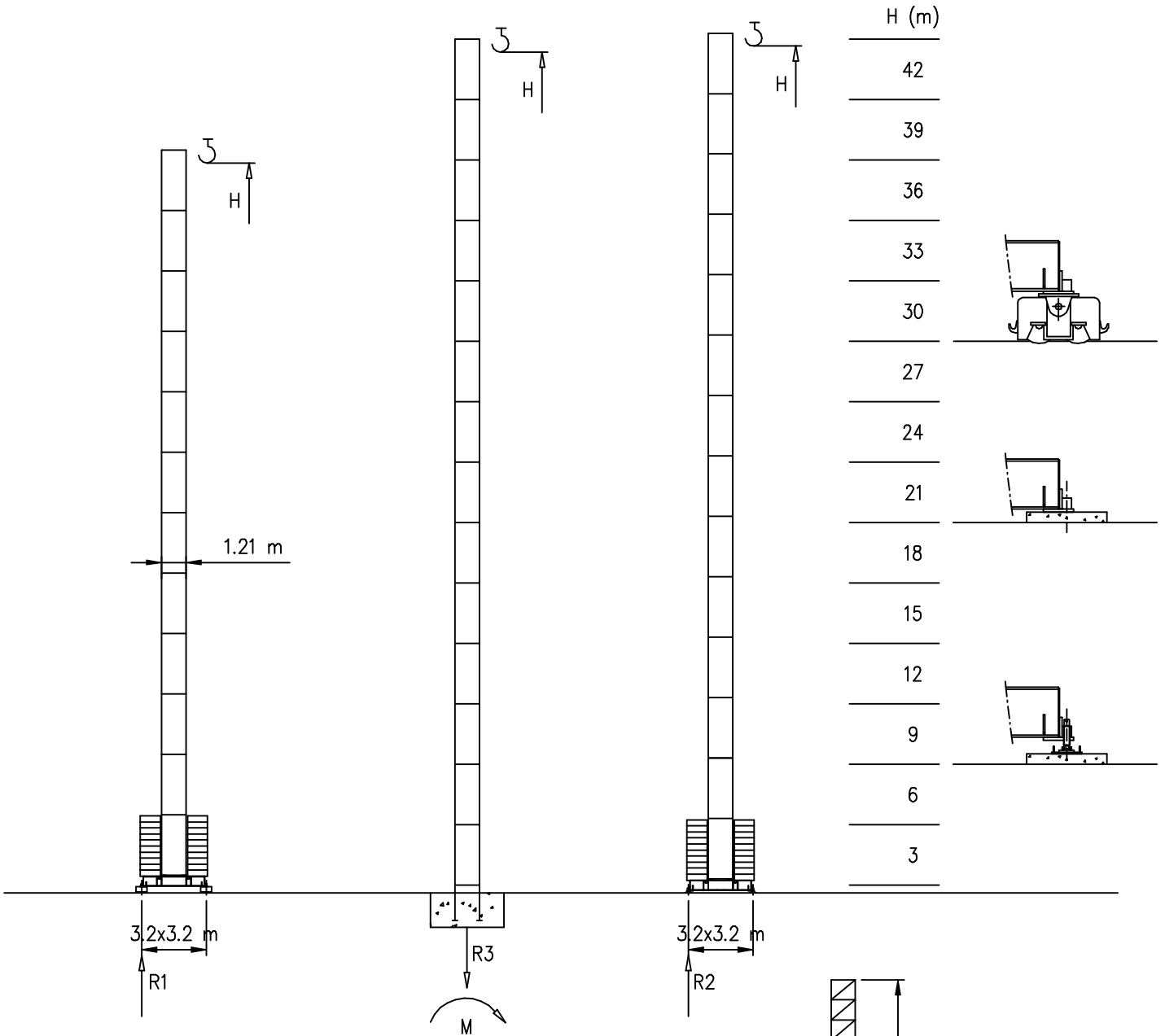

H=37-42 m		H=31-36 m		H=19-30 m		H=0-18 m	
R1		R1	26 t	R1	21 t	R1	18 t
R2	69 t	R2	25 t	R2	20 t	R2	17 t
R3	40 t	R3	20 t	R3	19 t	R3	17 t
M	185 tm	M	48 tm	M	40 tm	M	28 tm

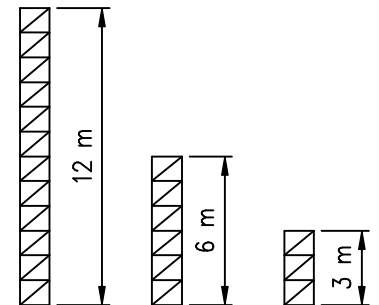

Peso zavorra – Ballast weight – Poids du lest – Ballastgewicht – Peso de lastre

H	n°	Tot.
0-18 m	6 A	18000 kg
19-30 m	8 A	24000 kg
30-36 m	12 A	36000 kg
37-42 m	24 A	72000 kg

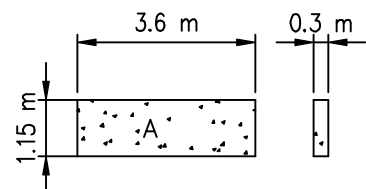

Curve di carico – Courbes de charges – Load diagrams – LastKurven – Curvas de cargas

Pmax 1800 kg

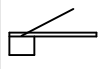
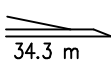
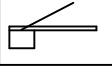
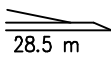
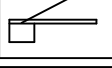
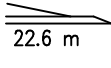
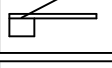
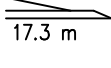
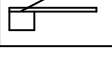
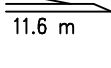
	5460 kg		2	19.0	22.6	28.5	34.3	m
			1800	1800	1500	1200	1000	kg
	4380 kg		2	21.0	22.6	28.5		m
			1800	1800	1680	1350		kg
	3810 kg		2		22.6			m
			1800		1800			kg
	2730 kg		2				17.3	m
			1800				1800	kg
	1650 kg		2				11.6	m
			1800				1800	kg

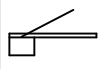
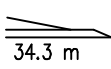
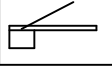
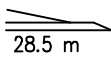
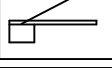
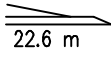
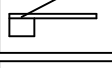
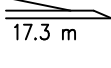
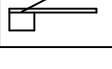
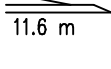

Pmax 2400 kg

	5460 kg		2	15.5	19.0	22.6	28.5	34.3	m
			2400	2400	1800	1500	1200	1000	kg
	4380 kg		2	17.3	21.0	22.6	28.5		m
			2400	2400	1800	1680	1350		kg
	3810 kg		2		19.0	22.6			m
			2400		2400	1800			kg
	2730 kg		2					17.3	m
			2400					2400	kg
	1650 kg		2					11.6	m
			2400					2400	kg



Montaggio – Montage – Erection – Montage – Montaje – Montagem







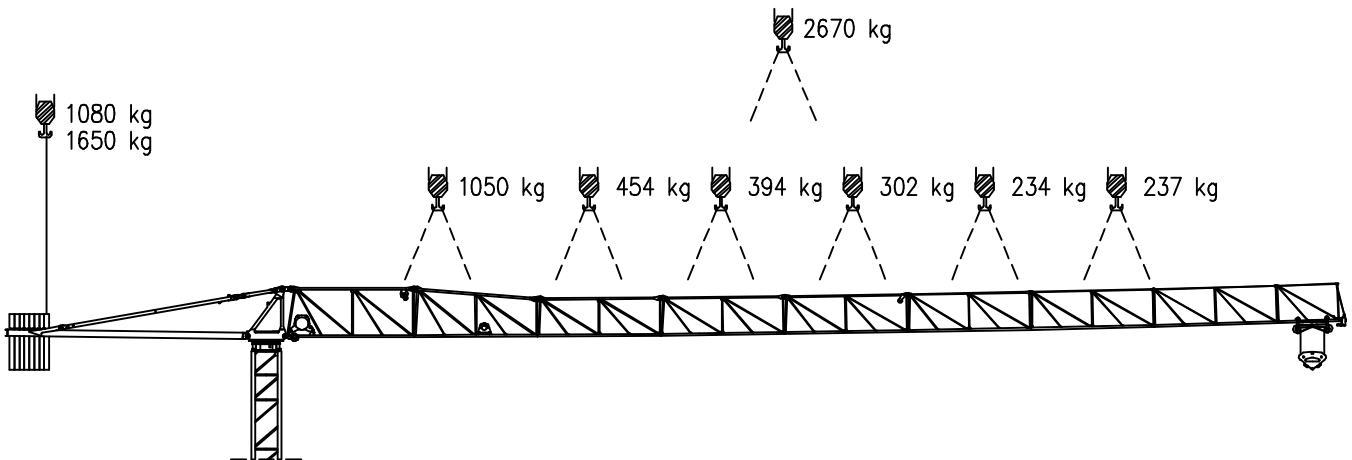
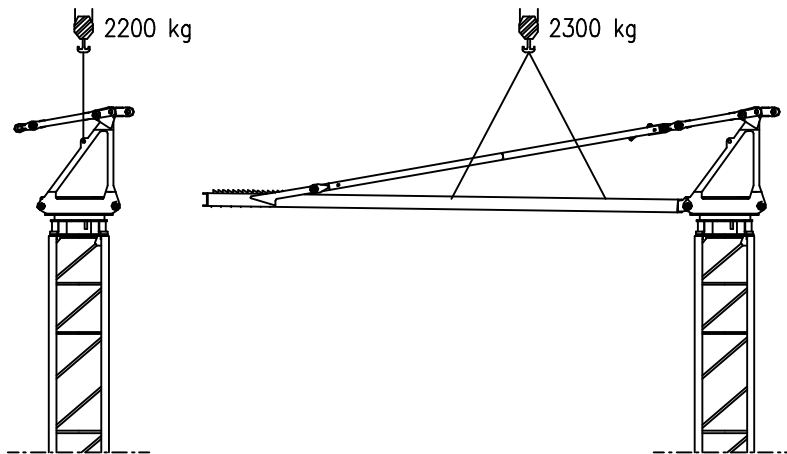
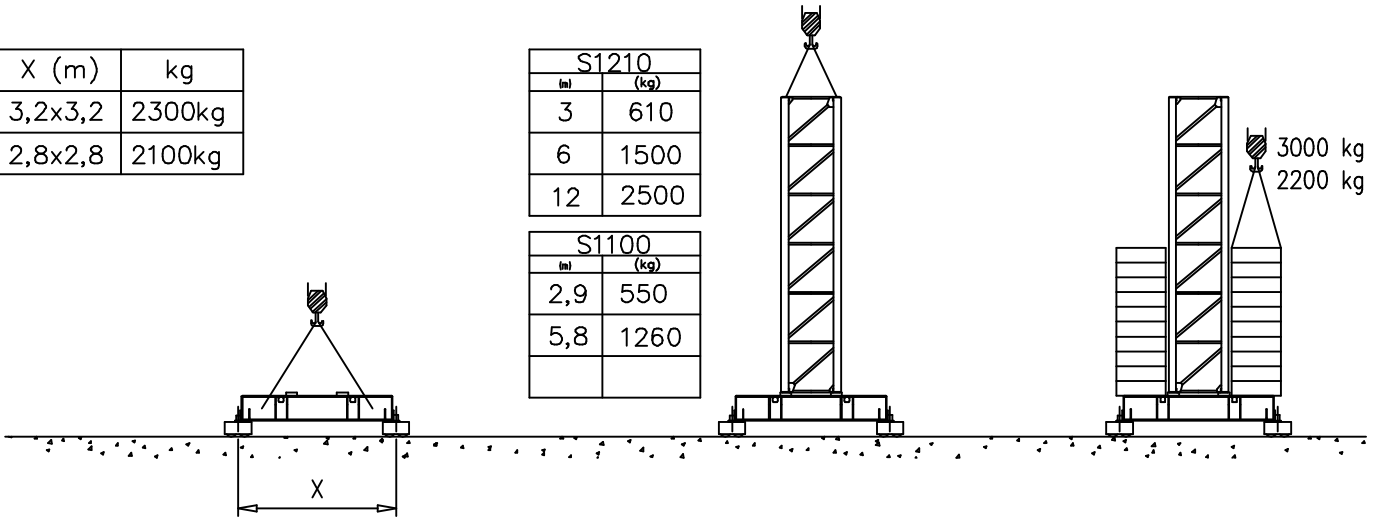

X (m)	kg
3,2x3,2	2300kg
2,8x2,8	2100kg

S1210	
lnl	(kg)
3	610
6	1500
12	2500

S1100	
lnl	(kg)
2,9	550
5,8	1260



Meccanismi – Mechanisms – Mécanismes – Antriebe – Mecanismos

Sollevamento M05.47 Hoisting Levage Heben Elevaciòn Elevaçao		1a	3 m/min	1800 kg	5.5 kW	19kVA	
		2a	16 m/min	1800 kg			
		3a	28 m/min	1000 kg			
		4a	* 40 m/min	600 kg			
		5a	* 47 m/min	300 kg			
		* OPTIONAL					
Sollevamento M07.47 Hoisting Levage Heben Elevaciòn Elevaçao		1a	3 m/min	2400 kg	7.5 kW	22kVA	
		2a	16 m/min	2400 kg			
		3a	36 m/min	1000 kg			
		4a	40 m/min	800 kg			
		5a	47 m/min	400 kg			
Carrello Trolleying Distribution Katzfahren Distribuciòn Distribuiçao			1a	5 m/min	1800 kg	1.1 kW	Potenza elettrica necessaria Puissance électrique nécessaire Necessary electric power Anschlusswert – Potencia
			2a	17 m/min	1800 kg		
			3a	34 m/min	1800 kg		
Rotazione Slewing Orientation Schwenken Orientaciòn Rotaçao			1a	0 → 0.2	giri/min	4 kW	
			2a	0 → 0.4	tr/min		
			3a	0 → 0.7	rp/min		
Traslazione Travelling Translation Kranfahren Traslaciòn Translaçao			1a	0 → 8	m/min	3.7 kW	
			2a	0 → 18			

Rete elettrica – Réseau – Mains supply – Netzstrom – Red – Rede electrica	400V – 50 Hz
	480V – 60 Hz

AFM Gru FMgru s.r.l.
via Emilia 11–29010 Pontenure PC ITALY
tel. 0523/510446 ric.aut. fax 0523/510365
www.fmgru.com e-mail: info@fmgru.com

FEM 1.001
2000/14/CE



Documento commerciale non contrattuale
Per tutte le informazioni tecniche riferirsi
alle corrispondenti istruzioni

Unverbindliches Vertriebsdokument.
Für technische Informationen, siehe die
entsprechenden Anweisungen.

This commercial document is not legally
binding. For any technical information, please
refer to the corresponding instructions.

Documento comercial no contractual
Para cualquier información técnica,
ver la noticia correspondiente.

Code: 15ICA37T10A0			
Ed.	Data	Rev	Data
1	30.08.06	0	30.08.06