

Turmdrehkran

Tower Crane / Grue à tour / Gru a torre
Grúa torre / Guindaste de torre

154 EC-HM 6 FR.tronic®

▶ **154 EC-HM 6 FR.tronic®**

154 EC-HM 10 FR.tronic®

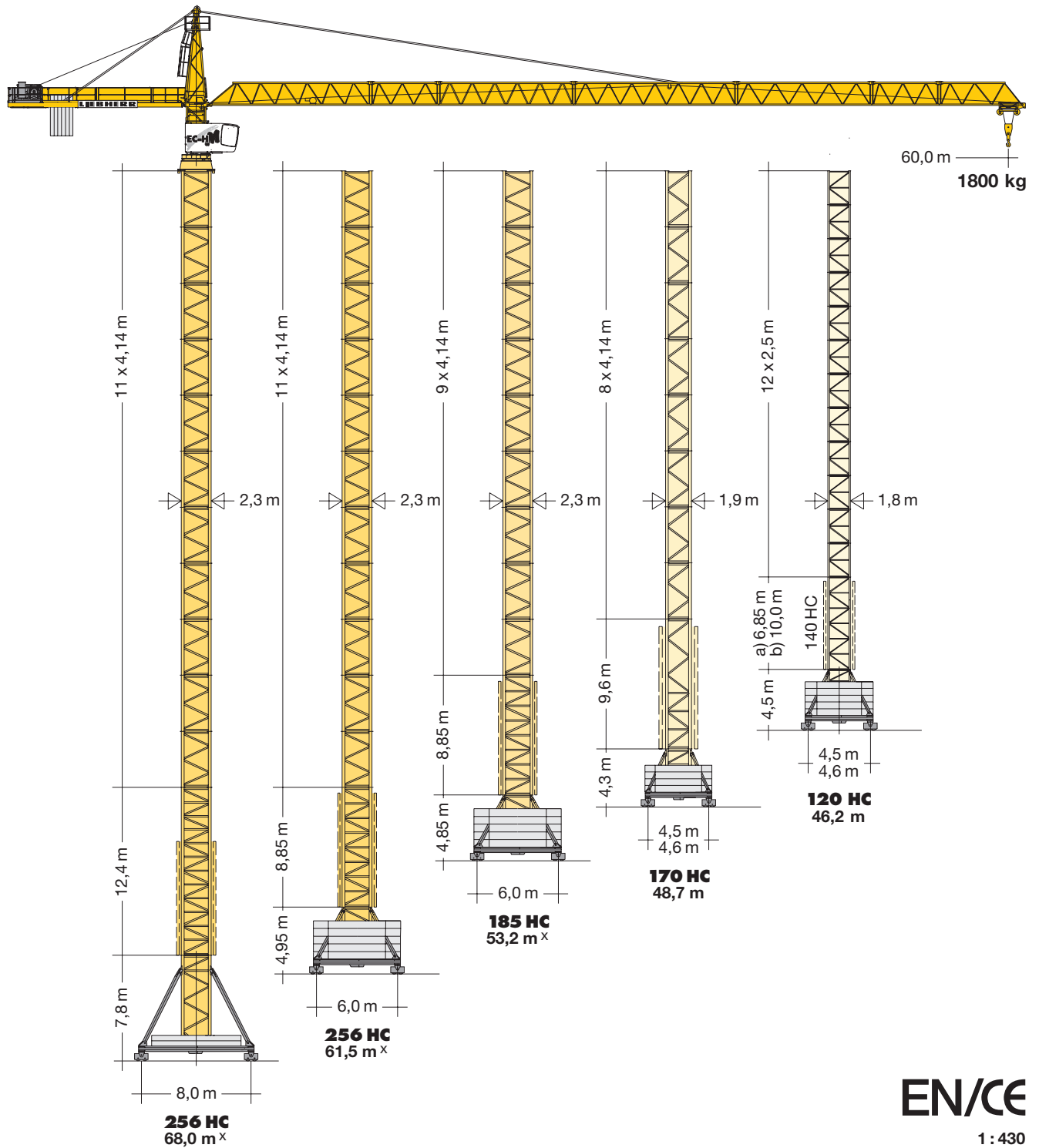

LIEBHERR

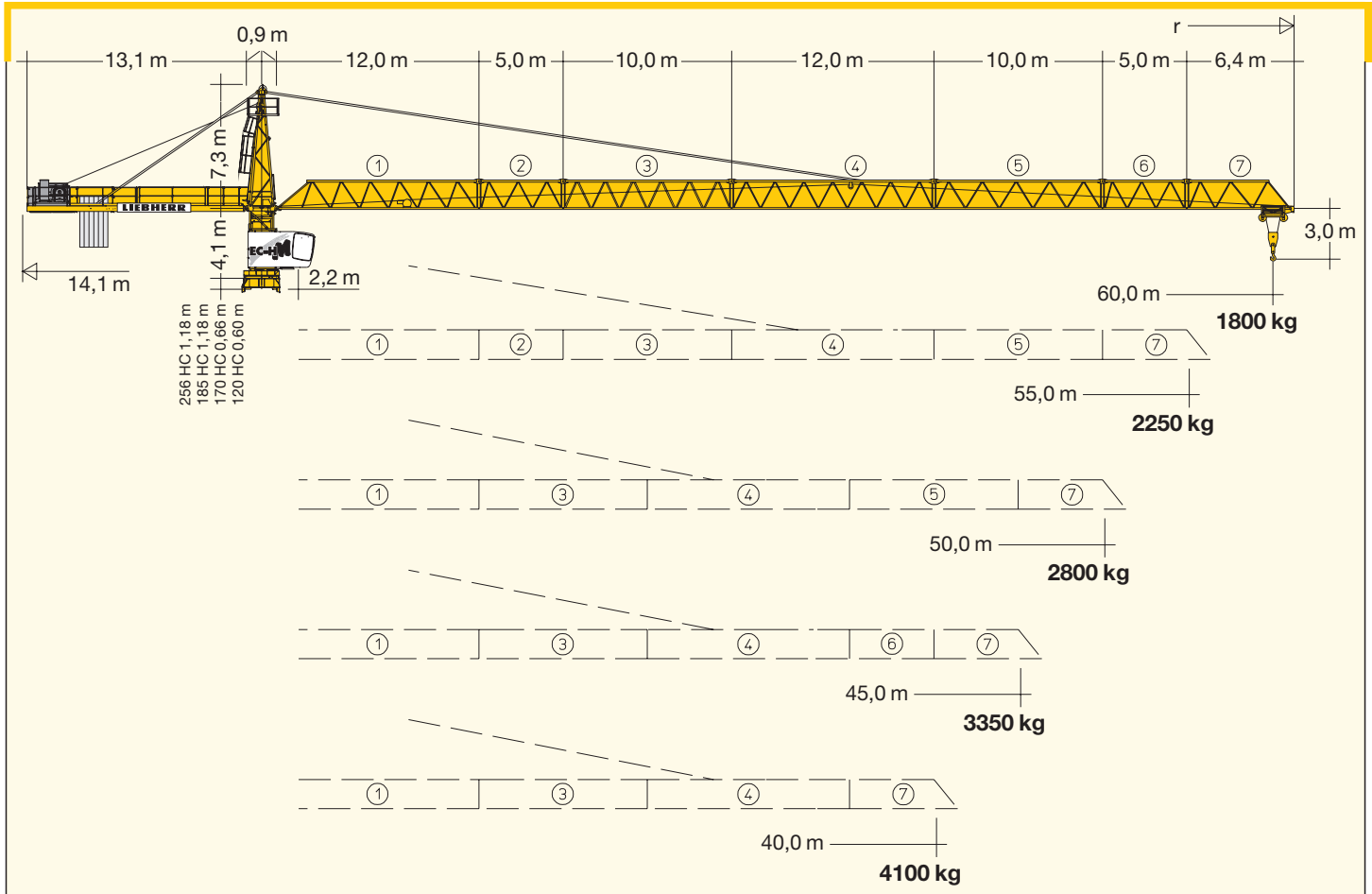

Hubhöhe

Hoisting height / Hauteur sous crochet / Altezza di sollevamento / Altura bajo gancho / Altura de montagem

| 120 HC | | | | | | | | | | | | |
|--------|--------------------|--------------------|---------------------|--------------------|--------------------|--------------------|--------------------|--------------------|--------------------|-------------------|-------------------|---------------------|
| 12 | 43,0 ^{*o} | 46,2 ^{*o} | - | 42,5 ^{*o} | 45,7 ^{*o} | 38,8 ^{*o} | 42,0 ^{*o} | - | - | - | - | - |
| 11 | 40,5 [*] | 43,7 [*] | 53,7 ^{**o} | 40,0 [*] | 43,2 [*] | 36,3 [*] | 39,5 [*] | 46,3 ^{*o} | 49,5 ^{*o} | 37,7 [*] | - | 50,8 ^{**o} |
| 10 | 38,0 | 41,2 | 51,2 [*] | 37,5 | 40,7 | 33,8 | 37,0 | 43,8 [*] | 47,0 [*] | 35,2 [*] | 38,4 [*] | 48,3 ^{**} |
| 9 | 35,5 | 38,7 | 48,7 [*] | 35,0 | 38,2 | 31,3 | 34,5 | 41,3 | 44,5 | 32,7 | 35,9 [*] | 45,8 [*] |
| 8 | 33,0 | 36,2 | 46,2 | 32,5 | 35,7 | 28,8 | 32,0 | 38,8 | 42,0 | 30,2 | 33,4 | 43,3 |
| 7 | 30,5 | 33,7 | 43,7 | 30,0 | 33,2 | 26,3 | 29,5 | 36,3 | 39,5 | 27,7 | 30,9 | 40,8 |
| 6 | 28,0 | 31,2 | 41,2 | 27,5 | 30,7 | 23,8 | 27,0 | 33,8 | 37,0 | 25,2 | 28,4 | 38,3 |
| 5 | 25,5 | 28,7 | 38,7 | 25,0 | 28,2 | 21,3 | 24,5 | 31,3 | 34,5 | 22,7 | 25,9 | 35,8 |
| 4 | 23,0 | 26,2 | 36,2 | 22,5 | 25,7 | 18,8 | 22,0 | 28,8 | 32,0 | 20,2 | 23,4 | 33,3 |
| 3 | 20,5 | 23,7 | 33,7 | 20,0 | 23,2 | 16,3 | 19,5 | 26,3 | 29,5 | 17,7 | 20,9 | 30,8 |
| 2 | 18,0 | 21,2 | 31,2 | 17,5 | 20,7 | 13,8 | 17,0 | 23,8 | 27,0 | 15,2 | 18,4 | 28,3 |
| 1 | 15,5 | 18,7 | 28,7 | 15,0 | 18,2 | 11,3 | 14,5 | 21,3 | 24,5 | 12,7 | 15,9 | 25,8 |
| 0 | 13,0 | 16,2 | 26,2 | 12,5 | 15,7 | 8,8 | 12,0 | 18,8 | 22,0 | 10,2 | 13,4 | 23,3 |
| | m a) | b) | | m a) | b) | m a) | b) | a) | b) | m a) | b) | m |



O = Ohne Kabine
Without cabin
Sans cabine
Senza cabina
Sin cabina
Sem cabine

S = verstärkt
reinforced
renforcé
rinforzato
reforzado
reforçado



Klettern im Gebäude auf Anfrage
Climbing inside building on request
Télescopage en bâtiment sur demande
Telescopaggio all'interno dell'edificio, su richiesta
Para trepado en el interior del edificio, consultar
Subida no edificio, conforme ao pedido

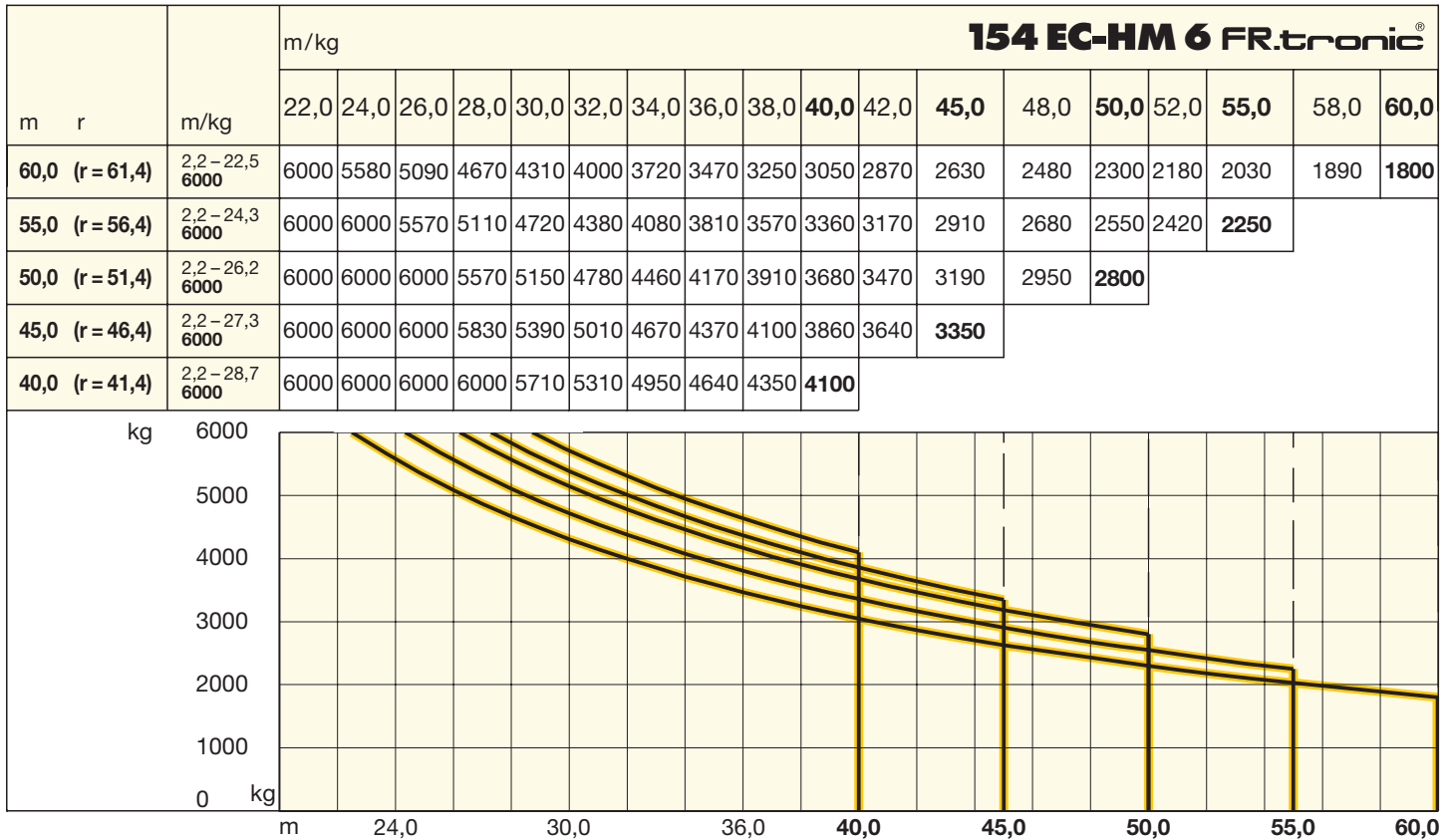

Hubhöhe

Hoisting height / Hauteur sous crochet / Altezza di sollevamento / Altura bajo gancho / Altura de montagem





| | 170 HC | | 185 HC | | | 256 HC | | | | |
|----|-------------------|-------------------|-------------------|-------------------|-------------------|---------------|---|---|-------------------|--------------------|
| 12 | – | – | – | – | – | – | – | – | 64,6 ^x | – |
| 11 | – | – | – | – | – | – | – | – | 60,4 [*] | 68,0 ^{*o} |
| 10 | – | – | 52,8 ^x | – | – | – | – | – | 56,8 [*] | 63,8 ^{*o} |
| 9 | 48,8 [*] | – | 48,7 [*] | 53,2 [*] | 50,0 [*] | – | – | – | 52,7 [*] | 57,4 ^{*o} |
| 8 | 44,7 [*] | 48,7 [*] | 44,5 | 49,1 [*] | 45,9 | – | – | – | 54,1 [*] | 50,0 |
| 7 | 40,5 | 44,6 | 40,4 | 45,0 | 41,7 | – | – | – | 48,5 | 53,3 |
| 6 | 36,4 | 40,4 | 36,2 | 40,8 | 37,6 | – | – | – | 44,4 | 49,2 |
| 5 | 32,3 | 36,3 | 32,1 | 36,7 | 33,4 | – | – | – | 40,3 | 45,0 |
| 4 | 28,1 | 32,2 | 28,0 | 32,6 | 29,3 | – | – | – | 36,1 | 40,9 |
| 3 | 24,0 | 28,0 | 23,8 | 28,4 | 25,2 | – | – | – | 32,0 | 36,7 |
| 2 | 19,8 | 23,9 | 19,7 | 24,3 | 21,0 | – | – | – | 27,9 | 32,6 |
| 1 | 15,7 | 19,7 | 15,6 | 20,1 | 16,9 | – | – | – | 23,7 | 28,5 |
| 0 | 11,6 | 15,6 | 11,4 | 16,0 | 12,7 | – | – | – | 19,6 | 24,3 |
| | m | | m | | | m | | | m | |

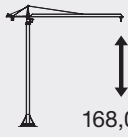
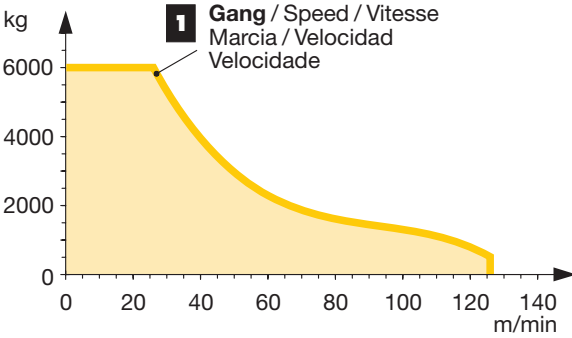

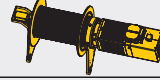
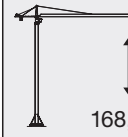
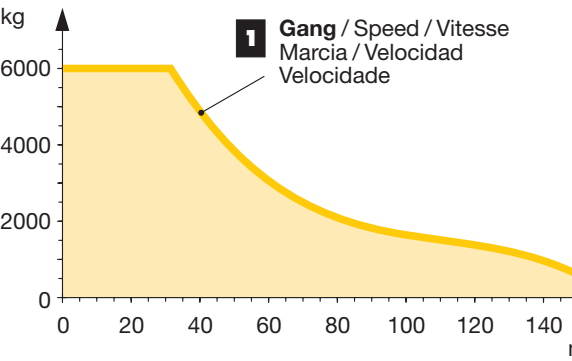



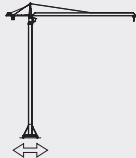















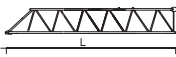

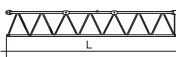

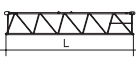







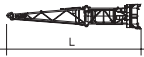



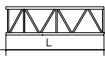

x = Nur bei Windzone C 10
 Only in case of wind zone C 10
 Seulement en cas de zone de vent C 10
 Solo in zona vento C 10
 Solo en zona de viento C 10
 Só em zona de vento C 10



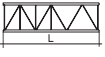

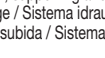
Weitere Hubhöhen in Abhängigkeit von Windzonen auf Anfrage
 Additional hoist heights depending on wind zones on request
 Hauteurs sous crochet supplémentaires dépendant des zones de vent sur demande
 A richiesta, ulteriori altezze di sollevamento a seconda delle zone vento
 Para otras alturas bajo gancho superiores en zonas de viento, consultar
 Para outras alturas de elevação em zonas de vento, conforme ao pedido

| | |
|---|---|
|  | <p>↔ stufenlos / stepless / régl. continu regl. progressiva / sin escalones / sem degraus kg m/min</p> |
| <p>30 kW FR.tronic-FU WIW 240 MZ 401</p> <p>5 Lagen Layers Couches Strati Camadas Capas</p> <p> 168,0 m</p> | <p>1 6000 0 ↔ 26 450 0 ↔ 126</p> |
| <p>1 Gang / Speed / Vitesse Marcia / Velocidad Velocidade</p>  | |

| | |
|---|---|
|  | <p>↔ stufenlos / stepless / régl. continu regl. progressiva / sin escalones / sem degraus kg m/min</p> |
| <p>37 kW FR.tronic-FU WIW 250 MZ 401</p> <p>5 Lagen Layers Couches Strati Camadas Capas</p> <p> 168,0 m</p> | <p>1 6000 0 ↔ 32 500 0 ↔ 152</p> |
| <p>1 Gang / Speed / Vitesse Marcia / Velocidad Velocidade</p>  | |

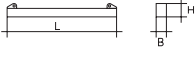
| | | | | | | |
|---|--|---|----------|----------|------|------|
|  | <p>U/min 0 ↔ 0,8 sl./min tr./min</p> | 1 x 7,5 kW FR.tronic-FU | | | | |
|  | 0 ↔ 100,0 m/min | 5,5 kW FR.tronic-FU | | | | |
|  | 25,0 m/min | <p>2 x 4,0 kW (120 HC) 2 x 7,5 kW (256 HC) 2 x 5,5 kW (185 HC, 170 HC)</p> | | | | |
|  | kVA | <table border="1"> <tr> <td>30 kW FU</td> <td>37 kW FU</td> </tr> <tr> <td>45,0</td> <td>50,0</td> </tr> </table> | 30 kW FU | 37 kW FU | 45,0 | 50,0 |
| 30 kW FU | 37 kW FU | | | | | |
| 45,0 | 50,0 | | | | | |

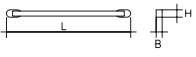
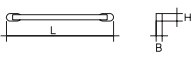
| Kranoberteil | | Upper part of crane / Partie supérieure de grue / Parte superiore della gru | | L (m) | B (m) | H (m) | kg* | | |
|-------------------------------|----------------------|--|--|---|--------------|--------------|-------------|-----------------|-------------|
| Pos. Item Rep. Voce Pos. Ref. | Anz. Qty. Qta. Cant. | | | | | | | | |
| 1 | 1 | Drehbühne / Slewing platform Plateforme tournante / Piattaforma girevole Plataforma de giro / Plataforma giratória |  |  | 120 HC | 5,20 | 2,30 | 2,27 | 6500 |
| | | | | | 170 HC | 5,20 | 2,30 | 2,27 | 6700 |
| | | | | | 185 HC | 6,00 | 2,74 | 2,27 | 6900 |
| | | | | | 256 HC | 6,00 | 2,74 | 2,27 | 6900 |
| 2 | 1 | Kabine / Cabin Cabine / Cabina Cabina / Cabina |  |  | 4,05 | 1,55 | 2,34 | 1000 | |
| 3 | 1 | Turmspitze / Tower head section Porte-flèche / Testa porta-braccio Cabeça de apoio de lança / Cabeza de torre |  |  | 7,30 | 1,48 | 1,75 | 1870 | |
| 4 | 1 | Hubwerkseinheit / Hoist gear unit / Treuil de levage Gruppo meccanismo sollevamento / Mecanismo de elevación / Grupo de mecanismo elevatório | 37 kW  |  | 2,34 | 2,20 | 1,60 | 2400 | |
| 5 | 1 | Gegenausleger / Counter-jib Contre-flèche / Controbraccio Contra-pluma / Contra-lança |  |  | 13,11 | 2,42 | 0,57 | 3000 | |
| 6 | 1 | Gegenausleger mit Hubwerkseinheit Counter-jib with hoist gear unit / Contre-flèche avec treuil de levage / Controbraccio con gruppo meccanismo sollevamento / Contra-pluma con mecanismo de elevación / Contra-lança com grupo de mecanismo elevatório |  |  | 13,11 | 2,42 | 2,20 | 7000 | |
| 7 | 1 | Ausleger-Anlenkstück / Jib heel section Pied de flèche / Settore articolato di braccio Base articulada de lança / Pluma tramo primero |  |  | 12,24 | 1,58 | 1,79 | ① 2220 | |
| 8 | 1 | Ausleger-Zwischenstück / Intermediate jib section Élément intermédiaire de flèche / Spezzone di braccio Peça suplementar da lança / Tramo intermedio pluma |  |  | 12,30 | 1,25 | 1,70 | ④ 1640 | |
| 9 | 2 | Ausleger-Zwischenstück / Intermediate jib section Élément intermédiaire de flèche / Spezzone di braccio Peça suplementar da lança / Tramo intermedio pluma |  |  | 10,30 | 1,25 | 1,70 | ③ 1130 ⑤ 750 | |
| 10 | 2 | Ausleger-Zwischenstück / Intermediate jib section Élément intermédiaire de flèche / Spezzone di braccio Peça suplementar da lança / Tramo intermedio pluma |  |  | 5,25 | 1,25 | 1,68 | ⑥ 370 ② 630 | |
| 11 | 1 | Ausleger-Kopfstück / Jib head Pointe de flèche / Punta freccia Cabeça de lança / Tramo punta de pluma |  |  | 6,51 | 1,43 | 1,88 | ⑦ 500 | |
| 12 | 1 | Laufkatze und Lasthaken / Trolley and hook Chariot de distribution et crochet / Carrello con gancio Carrito y gancho / Carro de ponte e gancho |  |  | 1,90 | 1,42 | 1,38 | 915 | |
| 13 | 1 | Drehbühne und Turmspitze / Slewing platform and tower head section / Ensemble mât-cabine et porte-flèche Piattaforma girevole e cuspidi / Plataforma de giro y cabeza torre / Plataforma giratória e cabeça de torre |  |  | 120 HC | 12,30 | 2,30 | 2,27 | 8300 |
| | | | | | 170 HC | 12,30 | 2,30 | 2,27 | 8560 |
| | | | | | 185 HC | 12,70 | 2,74 | 2,27 | 8870 |
| | | | | | 256 HC | 12,70 | 2,74 | 2,27 | 8870 |
| 14 | 1 | Ausleger- und Gegenausleger-Abspannung / Jib and counter-jib suspension Haubanage de flèche et de contre-flèche / Attrezzatura di ancoraggio di braccio e controbraccio Tirantes de sost en pluma y contra-pluma / Grupo de ancoragem de lança e contra-lança |  |  | 8,20 | 0,55 | 0,12 | 1170 | |
| | | | | | 5,87 | 0,20 | 0,16 | 380 | |
| Turm | | Tower / Mât / Torre | | | | | | | |
| 15 | 13 9 9 11 | Turmstück / Tower section Élément de mât / Elemento di torre Torre / Torre |  |  | 120 HC | 2,50 | 1,80 | 1,80 | 1050 |
| | | | | | 170 HC | 4,14 | 1,90 | 1,90 | 1850 |
| | | | | | 185 HC | 4,14 | 2,30 | 2,30 | 2050 |
| | | | | | 256 HC | 4,14 | 2,30 | 2,30 | 2260 |
| 16 | 7 3 | Turmstück lang / Long tower section Élément de mât long / Elemento di torre, lungo Tramo de torre largo / Peça de torre, comprida |  |  | 120 HC | 5,00 | 1,80 | 1,80 | 1960 |
| | | | | | 120 HC | 10,00 | 1,80 | 1,80 | 3400 |
| | | | | | 120 HC | 12,50 | 1,80 | 1,80 | 4200 |
| 17 | 1 | Grundturmstück / Base tower section Mât de base / Elemento di torre base Tramo torre base / Peça de base de torre |  |  | 140 HC | 6,85 | 1,80 | 1,80 | 2930 |
| | | | | | 140 HC | 10,00 | 1,80 | 1,80 | 3990 |
| | | | | | 140 HC s | 10,00 | 1,80 | 1,80 | 4000 |
| | | | | | 170 HC | 9,60 | 1,90 | 1,90 | 4480 |
| | | | | | 185 HC | 8,85 | 2,30 | 2,30 | 4280 |
| | | | | | 256 HC | 8,85 (12,42) | 2,30 (2,30) | 2,30 (2,30) | 4830 (7940) |
| Klettereinrichtung | | Climbing equipment / Equipement de télescopage / Attrezzatura per allungamento della gru | Equipo de trepado / Acsórios p. subida no edificio | | | | | | |
| 18 | 1 | Führungsstück kpl. / Guide section cpl. Cage télescopique cpl. / Gabbia di sopraelevazione compl. Peça de guia compl. / Torre de montaje completa |  |  | 120 HC | 6,45 | 2,10 | 2,42 | 2660 |
| | | | | | 120 HC | 9,60 | 2,10 | 2,42 | 4410 |
| | | | | | 170 HC | 9,04 | 2,31 | 2,28 | 4750 |
| | | | | | 185 HC | 8,39 | 2,68 | 2,58 (3,04) | 5100 |
| | | | | | 256 HC | 8,39 | 2,68 | 2,58 (3,04) | 5100 |
| 19 | 1 | Hydraulikanlage, Stütz- und Klettertraverse / Hydraulic unit, supporting and climbing cross members Système hydraulique avec traverses d'appui et de télescopage / Sistema idraulico, traversa di appoggio e allungamento gru / Instalação hidráulica, travessa de apoio e subida / Sistema hidráulico con traviesa de apoyo y trepado |  |  | 120 HC | 2,87 | 2,12 | 1,06 | 1050 |
| | | | | | 170 HC | 2,00 | 1,10 | 1,00 | 1100 |
| | | | | | 185 HC | 2,30 | 1,25 | 1,00 | 1150 |
| | | | | | 256 HC | 2,30 | 1,25 | 1,00 | 1150 |
| Unterwagen | | Undercarriage / Châssis / Carro della gru | Carro con mástil / Carro de guindaste | | | | | | |
| 20 | 2 | Fahrschemel mit Antrieb / Rail bogie with drive Bogie moteur / Telaio con gruppo propulsore Quadro sem grupo de propulsão / Caja rodillo motriz |  |  | 120 HC | 1,38 | 0,88 | 0,87 | 900 |
| | | | | | 170 HC | 1,46 | 0,84 | 0,87 | 920 |
| | | | | | 185 HC | 1,46 | 0,84 | 0,87 | 920 |
| | | | | | 256 HC | 1,63 (1,46) | 0,92 (0,84) | 0,95 (0,87) | 1690 (920) |

| Pos. Item Rep. Voce Pos. Ref. | Anz. Qty. Qte. Qta. Cant. Cant. | | | | L (m) | B (m) | H (m) | kg* |
|--|--|---|---|--------|------------------------------|------------------------------|------------------------------|--------------------------|
| 21 | 2 | Fahrschemel ohne Antrieb / Rail bogie without drive Bogie fou / Telaio senza gruppo propulsore Quadro com grupo de propulsão / Caja rodillo conducido |  | 120 HC | 1,17 | 0,60 | 0,87 | 860 |
| | | | | 170 HC | 1,15 | 0,60 | 0,87 | 880 |
| | | | | 185 HC | 1,15 | 0,60 | 0,87 | 880 |
| | | | | 256 HC | 1,37 (1,15) | 0,62 (0,60) | 0,95 (0,87) | 1340 (880) |
| 22 | 1 | Tragholm lang / Long support arm Longeron long / Longherone lungo Brazo largo soporte / Travessa comprida |  | 120 HC | 7,12 | 0,78 | 0,65 | 950 |
| | | | | 170 HC | 7,15 | 0,80 | 0,70 | 1070 |
| | | | | 185 HC | 9,10 | 0,82 | 0,74 | 1350 |
| | | | | 256 HC | 9,10 (11,95) | 0,80 (0,82) | 0,80 (0,80) | 1650 (2200) |
| 23 | 2 | Tragholm kurz / Short support arm Longeron court / Longherone corto Brazo corto soporte / Travessa curta |  | 120 HC | 3,45 | 0,56 | 0,55 | 408 |
| | | | | 170 HC | 3,45 | 0,60 | 0,70 | 500 |
| | | | | 185 HC | 4,41 | 0,62 | 0,71 | 615 |
| | | | | 256 HC | 4,45 (5,58) | 0,77 (0,65) | 0,77 (0,77) | 800 (1035) |
| 24 | 2+2 | Randträger / Border support Traverse / Supporti base Traviesa / Apoio de bordo |  | 120 HC | 4,02 | 0,35 | 0,12 | 95 |
| | | | | 170 HC | 4,08 - 4,30 | 0,16 - 0,33 | 0,11 - 0,14 | 80 - 200 |
| | | | | 185 HC | 5,48 - 5,46 | 0,11 - 0,17 | 0,16 - 0,38 | 118 - 454 |
| | | | | 256 HC | 5,46 - 5,40 (7,52 - 7,46) | 0,11 - 0,18 (0,10 - 0,17) | 0,16 - 0,38 (0,10 - 0,38) | 175 - 525 (366 - 912) |
| 25 | 4 | Stützholm / Support strut Hauban de châssis / Correnti di appoggio Tirante vertical / Travessa de apoio |  | 120 HC | 3,78 | 0,15 | 0,22 | 200 |
| | | | | 170 HC | 3,53 | 0,25 | 0,17 | 240 |
| | | | | 185 HC | 4,23 | 0,17 | 0,25 | 275 |
| | | | | 256 HC | 4,14 (6,55) | 0,18 (0,22) | 0,25 (0,25) | 320 (600) |
| 26 | 1 | Unterswagen-Turmstück / Undercarriage tower section Mât de châssis / Elemento di torre del carro Tramo de carro / Peça de torre do chassis |  | 120 HC | 3,50 | 2,06 | 2,06 | 1320 |
| | | | | 170 HC | 3,30 | 2,15 | 2,15 | 2000 |
| | | | | 185 HC | 3,73 | 2,52 | 2,52 | 1950 |
| | | | | 256 HC | 3,73 (6,70) | 2,62 (2,53) | 2,62 (2,53) | 2550 (3800) |
| 27 | 1 | Stapel Aufstiege und Podeste / Bundle of ladders and platforms Faisceau d'échelles et de plates-formes / Serie di scale e rampe Paquete de escaleras y plataformas / Escadas e patamares | | 120 HC | 3,50 | 1,20 | 1,00 | 1000 |
| 28 | 1 | Kiste mit Kleinteilen / Crate with small parts Caisse contenant des accessoires / Cassa con accessori Caja con accesorios / Caixa de acessórios | | | 2,00 | 1,00 | 1,00 | 2000 |

() **Angaben in Klammern gelten für 8 m-Unterswagen.** / The data in brackets are valid for an undercarriage of 8 m. / Les données techniques indiquées entre parenthèses sont valables pour un châssis de 8 m. / Caratteristiche in (..) valgono per carro di 8 m. / Los datos entre paréntesis son válidos para carro de 8 m. / Características em (..) válidas pelo chassis de 8 m.

* **Einzelgewichte.** / Single weights. / Poids individuels. / Pesì di componenti. / Pesos de peças componentes. / Pesos unitarios.

Konstruktionsänderungen vorbehalten!

Subject to alterations! / Sous réserves de modifications!
Si fa riserva di modifiche! / Salvo modificação da construação!
¡Sujeto a modificaciones!

Sämtliche Angaben erfolgen ohne Gewähr.

This information is supplied without liability.
Ces renseignements sont sans garantie. / Le indicazioni contenute si intendono salvo errori ed omissioni.
Declinamos toda responsabilidad derivada de la información proporcionada. / Declinamos qualquer
responsabilidade quanto à informação fornecida.