

Igo 32

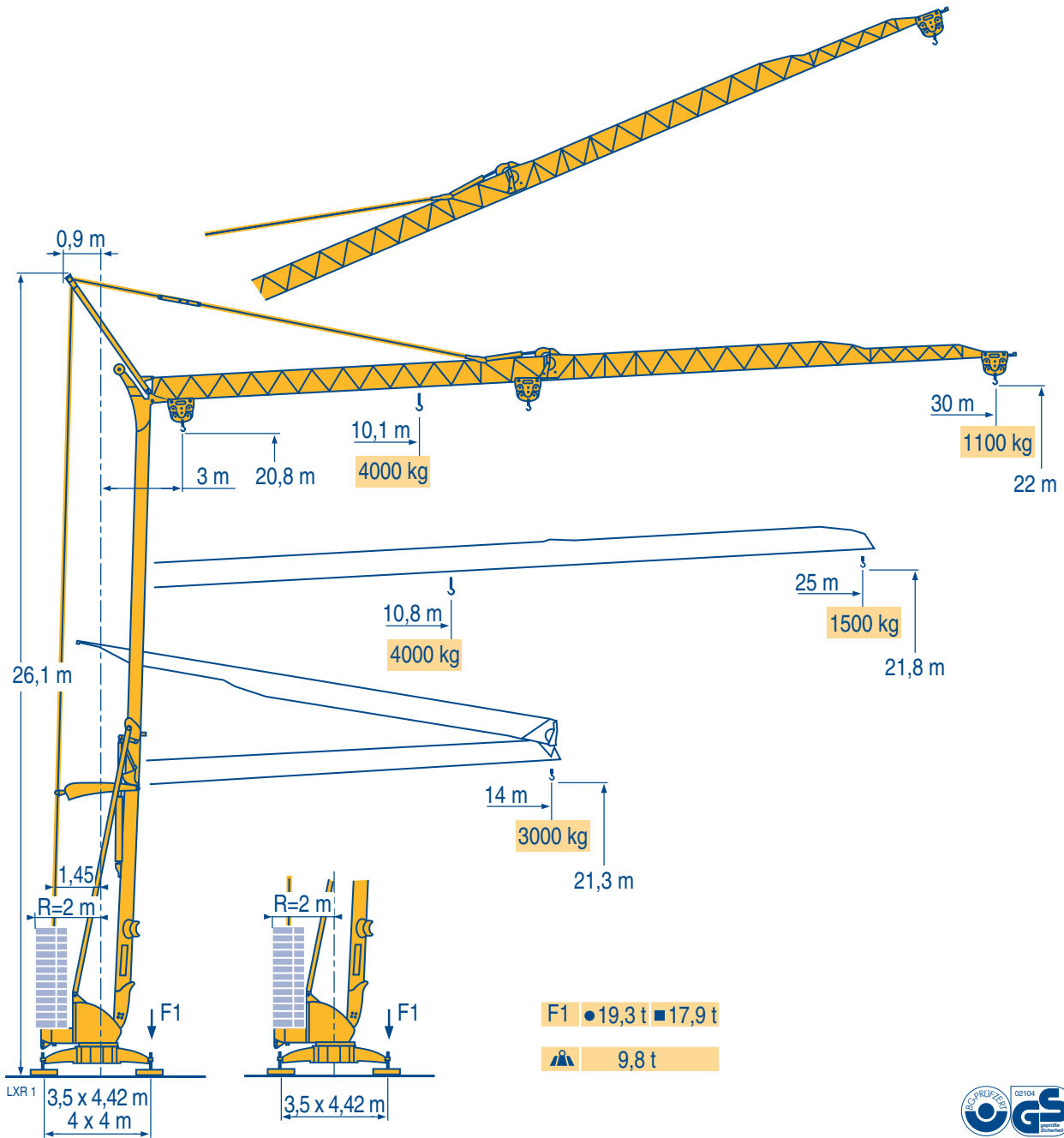

Courbes de charges

Lastkurven

Load diagrams

Curvas de cargas

Curve di carico

Curva de cargas

LXR 1

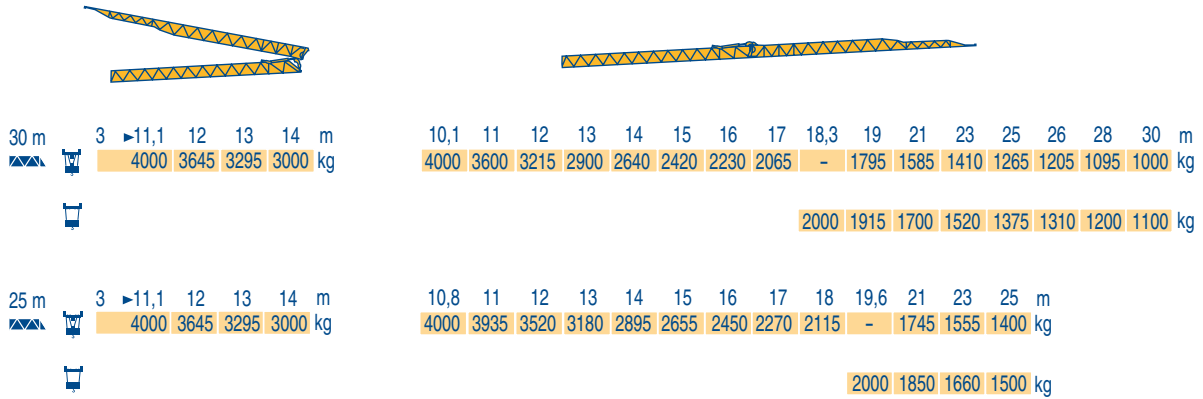

Flèche relevée

Ausleger in Steilstellung

Luffing jib

Flecha izada

Braccio impennato

Lança inclinada

LXR 1

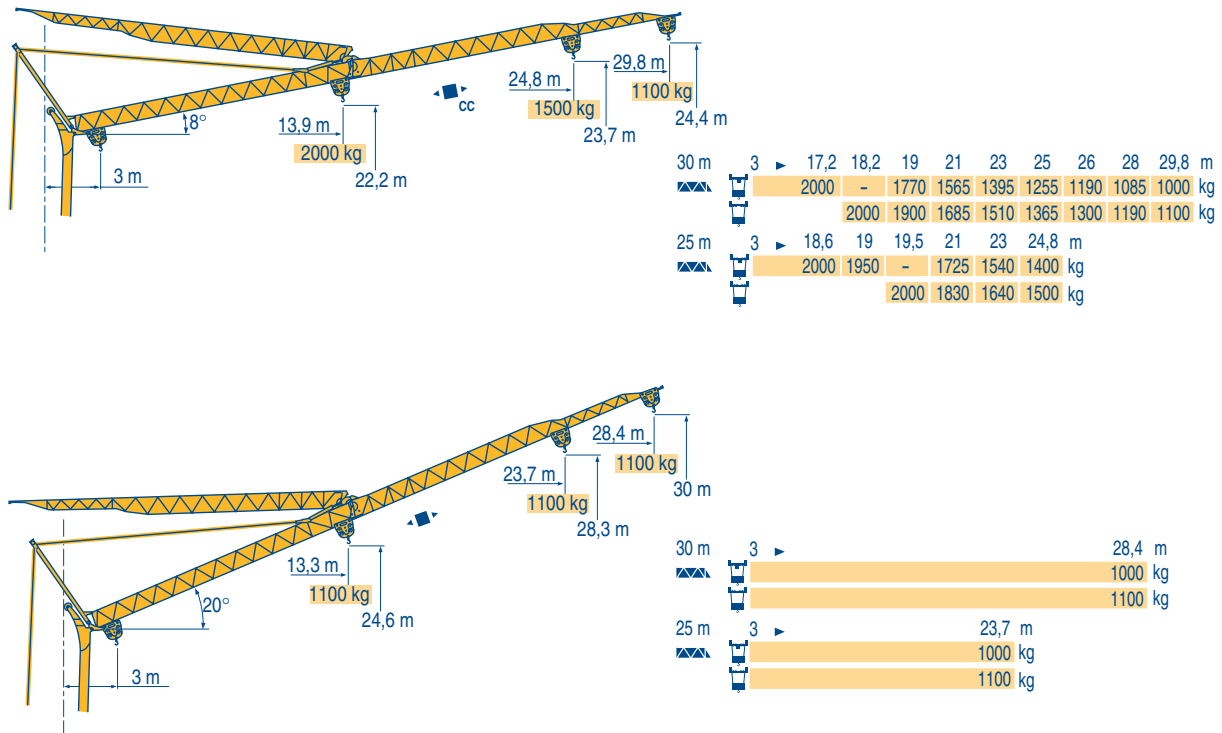

Igo 32

POTAIN



F
Chariot distributeur
Chariot distributeur et courbes de charges



Reactions in service



Reactions hors service
A vide sans lest (ni train de transport) avec flèche et hauteur maximum.



A vide sans lest (ni train de transport) avec flèche et hauteur maximum.

D

Verfahrbare Laufkatze
Verfahrbare Laufkatze und Lastkurven

Reaktionskräfte in Betrieb

Reaktionskräfte außer Betrieb

Ohne Last, Ballast (und Transportachse), mit Maximalausleger und Maximalhöhe.

GB

Traversing trolley
Traversing trolley and load diagrams

Reactions in service

Reactions out of service

Without load, ballast (or transport axes), with maximum jib and maximum height.

E

Carro distribuidor
Carro distribuidor y curvas de cargas

Reacciones en servicio

Reacciones fuera de servicio

Sin carga, sin lastre, (ni tren de transporte), flecha y altura máxima.

I

Carrellino distributore
Carrellino distributore e curve di carico

Reazioni in servizio

Reazioni fuori servizio

A vuoto, senza zavorra (ne assali di trasporto) con braccio massimo e altezza massima.

P

Carro distribuidor
Carro distribuidor e curva de cargas

Reações em serviço

Reações fora de serviço

Sem carga (nem trem de transporte)- sem lastro com lança e altura máximas.

Mécanismes
Antriebe
Mechanisms
Mecanismos
Meccanismi
Mecanismos

LXR 1

												ch - PS hp	kW	
▲ ● ▼	15 LVF 10 Optima	m/min	3,6	18	30	49	66						15	11
		kg	2000	2000	2000	1100	500							
		m/min	3,6	18	30	54	66	1,8	8,9	15	27	33		
		kg	2000	2000	2000	1000	500	4000	4000	4000	2000	1000		
◀ ■ ▶	3 DVF5	m/min	19 - 41										3	2,2
⊙	RVF2-30	tr/min U/min rpm	0 → 0,8										2	1,5
CEI 38		IEC 38	kVA					2000/14						
400 V (+6% -10%) 50 Hz			15 LVF 10 : 20 kVA											

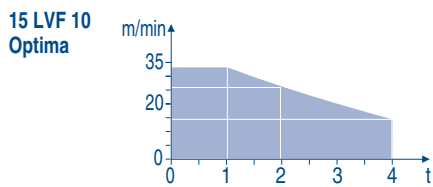

Montage
Montage
Erection
Montaje
Montaggio
Montagem

LXR 1

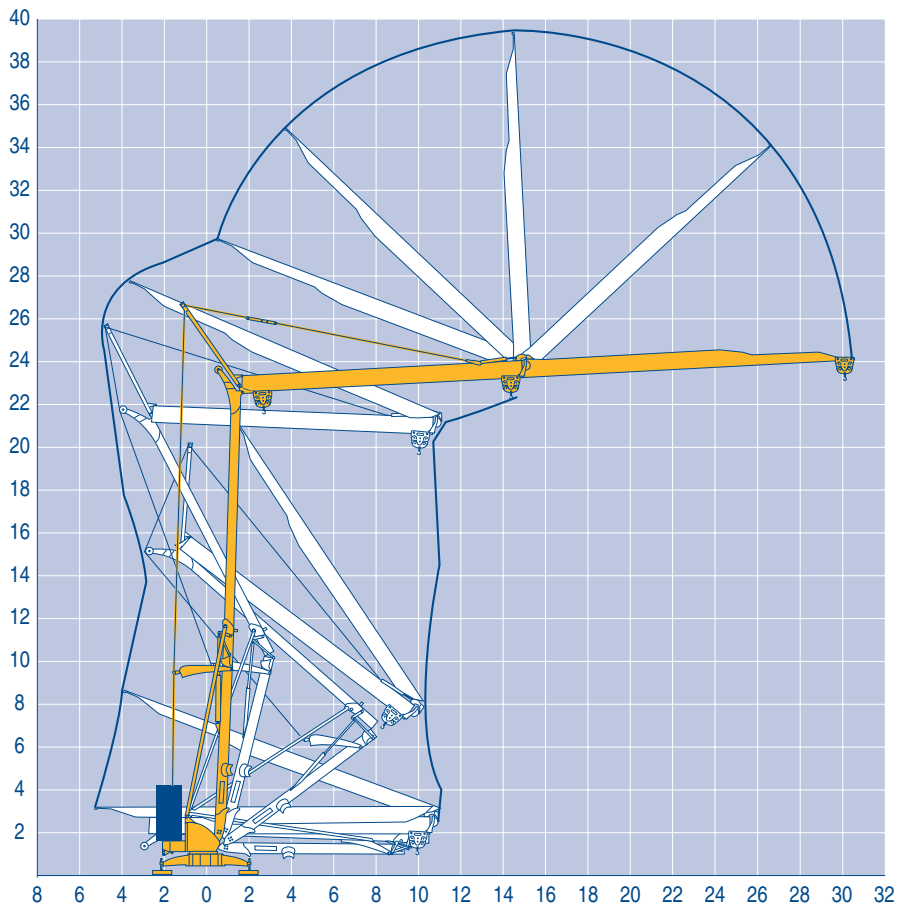

Igo 32

POTAIN



F	D	GB	E	I	P
Levage	Heben	Hoisting	Elevación	Sollevamento	Elevação
Distribution	Katzfahren	Trolleying	Distribución	Distribuzione	Distribuição
Orientation	Schwenken	Slewing	Orientación	Rotazione	Rotação
Conforme aux directives CEE sur le niveau acoustique	Gemäss EWG-Richtlinien für den Schall-Leistungspegel	In compliance with the EEC Instructions on noise level	Conforme con las directivas CEE sobre el nivel acustico	Conforme alle direttive CEE sul livello acustico	Conforme as directivas CEE sobre o nível acústico

Transport
Transport
Transport
Transporte
Trasporto
Transporte

LXR 2

		L (m)	B (m)	C (m)	D (m)	H (m)
DS61/S120	○					
DS61/S125		15,9	2,45	4	6,81	3,05/3,2
DJ80/S120	○	15,9	2,45	4	6,81	3,1
DJ80/S125		15,9	2,45	4	6,81	3,1
DJ100/S120		16,33	2,45	4	6,81	3,1/3,23
DJ105/S125		16,33	2,45	4	6,81	3,1/3,23
DJ126M/S125		16,35	2,45	4	6,81	3,2
DJ126M/S215M		17,14	3,24	4,07	6,74	3,55

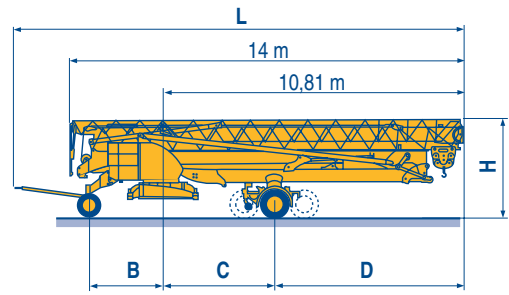

		C (m)	D (m)
SL122/J215M			
SL121/J135	SL122/J215M	4,07	6,74
SL121/S215M	SL121/J135	4	6,81
	SL121/S215M	4,07	6,74

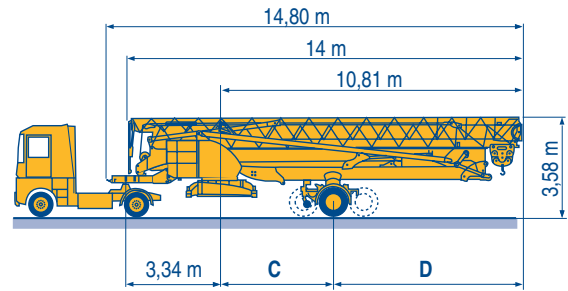

	F	D	GB	E	I	P
○	Chantier	Baustelle	Site	Obra	Cantiere	Estaleiro



Document commercial non contractuel. Pour toute information technique se référer à la notice correspondante

Unverbindliches Vertriebsdokument. Für technische Informationen, siehe die entsprechenden Anweisungen.

This commercial document is not legally binding. For any technical information, please refer to the corresponding instructions.

Documento commercial no contractual. Para cualquier información técnica, ver la noticia correspondiente.

Documento commerciale non vincolante. Per tutte le informazioni tecniche fare riferimento al catalogo istruzioni

Documento comercial não contractual. Para qualquer informação técnica complementar consultar as respectivas instruções



Americas

Tel: +1 920 683 6322
Tel: +1 717 597 8121

Europe - Middle East - Africa

Tel: +(33) 4 72 81 50 00
Tel: +(44) 191 565 6281

Asia - Pacific

Tel: +(65) 6861 7133
Fax: +(65) 6862 4142

www.manitowoccrane.com

18, rue de Charbonnières - B.P.173
69132 ECULLY Cedex - France

Tél. : (33) 4 72 18 20 20
Fax. : (33) 4 72 18 20 00
www.manitowoccrane.com www.potain.com

Igo 32

Réf. 2003 48 LXR 2

Copyright.Reproduction interdite © POTAIN 2003

Réalisation HeadLines